

### ■ Features

- Busbar type
- High current
- Standard performance
- Very compact & light weight
- Safety cover for dust
- Standard type

### ■ Typical Applications

- Solar inverter
- ESS, PCS
- AVR, UPS, Inverter, Converter
- Motor drive Equipments
- Various industrial applications

### ■ Technical specifications

Items	BBA-5150-SD	BBA-5200-SD	BBA-5250-SD	BBA-5300-SD	BBA-5400-SD	BBA-5500-SD	BBA-5600-SD
Rated Voltage (V <sub>R</sub> )	3Ø, 500Vac						
Operating frequency	50 / 60Hz						
Rated Currents @40°C (I <sub>R</sub> )	150A	200A	250A	300A	400A	500A	600A
Withstanding voltage test	Line to Earth : 2,828Vdc for 1min. or 3,200Vdc for 2sec. ( BHSTD-QUA-Q201 )						
Insulation resistance	500Vdc for 1min. 300MΩ Min. ( BHSTD-QUA-Q202 )						
Leakage current	100mA Max. at rated voltage ( BHSTD-QUA-Q203 )						
Voltage drop	1.0V Max. ( BHSTD-QUA-Q204 )						
Temperature range	25/100/21 (-25°C to +100°C), 20~95% RH at Operating & Storage						
Designed according to	IEC/EN 60939 / UL1283 / CSA 22.2 No.8						
Weight[Kg](Max.)	6.80	6.80	6.90	7.10	7.10	7.10	7.20

### ■ Circuit Diagram

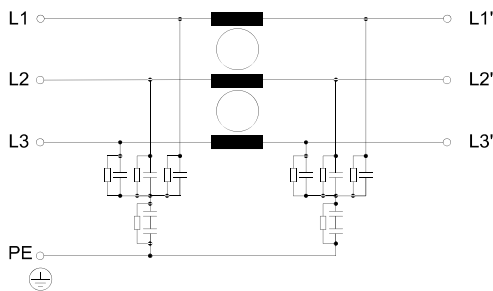

### ■ Shape & Dimension (mm)

See next page

### ■ Derating Curve

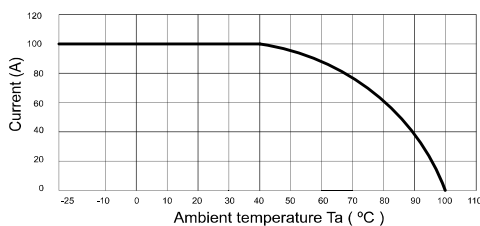

### ■ Lug ring terminal

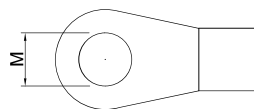

### ■ Recommended torque

- for M8 : 8.9 ~ 10.8 N · m
- for M10 : 18 ~ 23 N · m
- for M12 : 31 ~ 39 N · m

3Ø, 500Vac (150/200/250/300/400/500/600A) : 삼상 교류 500V 표준형

# BBA-5\*\*\*-SD Series (Standard type)

**BEMF**  
EMI/EMC FILTER

■ Shape & Dimension (mm)

**Basic type**

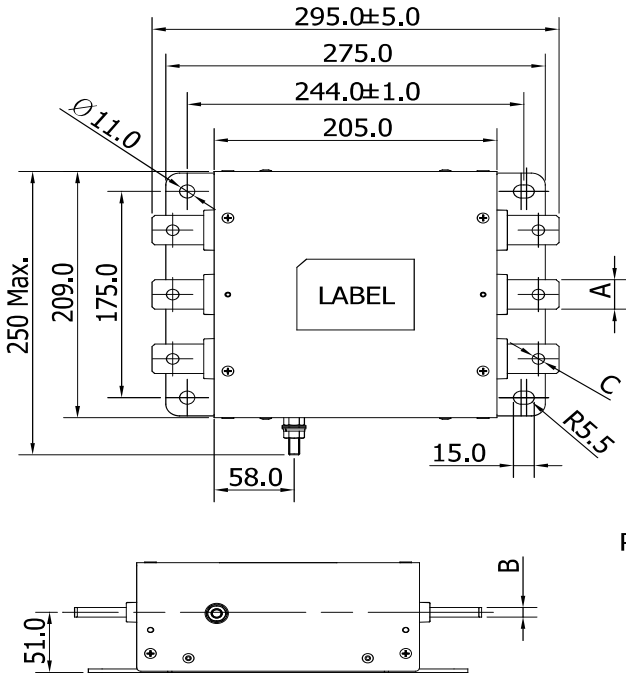

Rated current	A	B	C
150/200A	20	3	Ø9
250/300/400A	25	6	Ø11
500/600A	25	8	Ø13

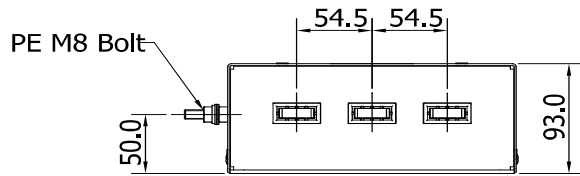

**Standard type ( with terminal protection cover )**

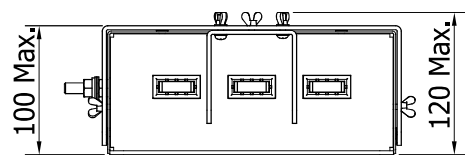
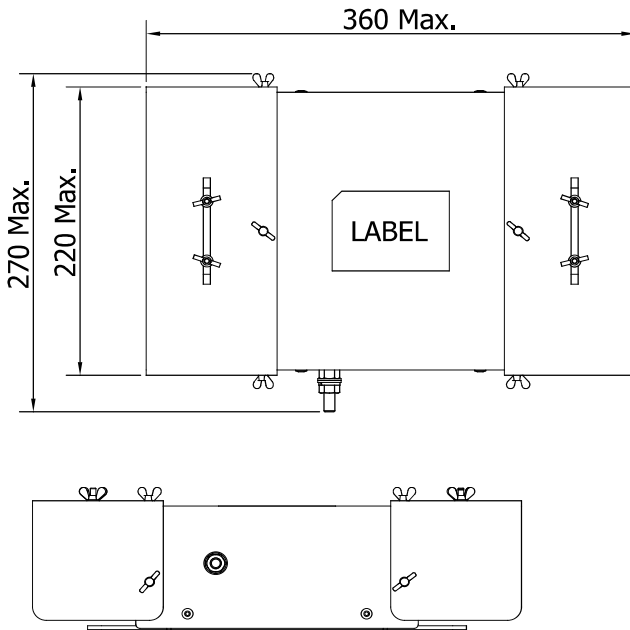

TO THE WORLD BUMHAN ● WE MAKE FOR YOU ● TO THE WORLD BUMHAN ● WE MAKE FOR YOU ● TO THE WORLD BUMHAN ● WE MAKE FOR YOU ● TO THE WORLD BUMHAN