

### ■ Features

- For 3phase 4wire system
- High performance
- Multi stage
- Space saving design
- Low cost

### ■ Typical Applications

- Industrial machinery
- AVR, UPS, Inverter, Converter
- Motor drive equipments
- Factory automation equipment
- ACB Panel, distribution Panel

### ■ Technical specifications

Items	BT4-5010-MS	BT4-5020-MS	BT4-5030-MS
Rated Voltage (V <sub>R</sub> )	3Ø, 500Vac		
Operating frequency	50 / 60Hz		
Rated Currents @40°C (I <sub>R</sub> )	10A	20A	30A
Withstanding voltage test	Line to Earth : 2,828Vdc for 1min or 3,650Vdc for 2sec. ( BHSTD-QUA-Q201 )		
Insulation resistance	500Vdc for 1min, 300MΩ Min. ( BHSTD-QUA-Q202 )		
Voltage drop	2.0V Max. ( BHSTD-QUA-Q204 )		
Temperature range	25/100/21 (-25°C to +100°C), 20~95% RH at Operating & Storage		
Designed according to	IEC/EN 60939 / UL1283 / CSA 22.2 No.8		

### ■ Derating Curve

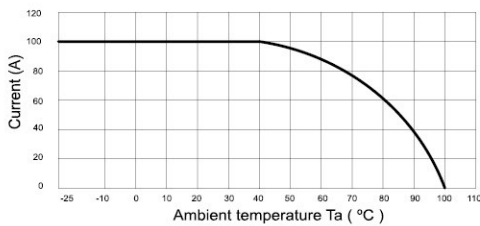

### ■ Shape & Dimension (mm)

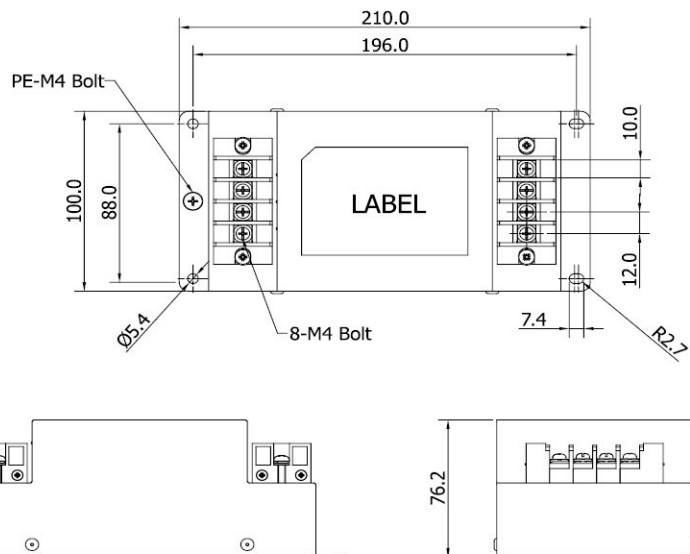

### ■ Lug ring terminal



### ■ Recommended torque

1.2 ~ 1.4 N · m